

Instructions for use  
—Type 2 Fix

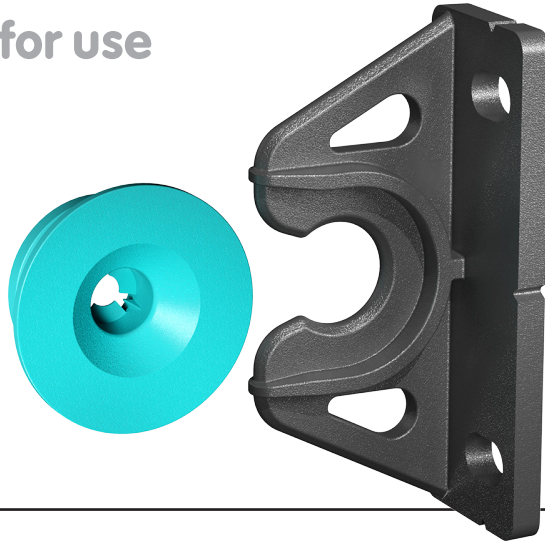

## Type 2 button-fix

The Button-fix concept is simple: durable Buttons are attached to the background structure and the mating Fixes are attached to the removable panel. Push firmly on the panel until the Button-fixes ‘click’.

The Type 2 Button-fix is moulded in nylon, connects panels at 90° and engages with a straight push. It is ideal for panels with no clearance above or at the side and applications where the emphasis is on ease of access.

Visit the website for more information on the complete Button-fix range, including videos of the Type 2 Button-fix in use. You can also obtain a new copy of these instructions from the website in the event of loss or in the event that Buttonfix modifies the instructions.

Buttonfix Limited retains the right to modify the instructions as it deems appropriate and the consumer is responsible for checking the website for the latest information.

### Warnings

—Button-fix is intended for furniture construction and interior fittings and is not intended, nor should it be used, for any other purpose.

—**WARNING:** Serious damage to property and severe bodily injury can result from (1) improper use, application or installation of the Button-fix or (2) use as part of improperly designed or constructed assemblies or materials.

—Provided that the screws and substrate are properly matched, and all other instructions complied with, tests showed that a vertical panel under no other loading than its own weight, fixed with four Type 2 Fixes, can weigh

up to a maximum of 50kg (110lbs). Other configurations should always be properly tested by the user to their satisfaction.

—Each Type 2 Fix requires approximately 7kg (15lbs) of force to separate the Button and Fix; this should be taken into account when designing your installation and defining your safety factors.

—**CAUTION:** Type 2 Fixes should only be used on vertical panels or in applications where the weight of the panel does not act to separate the fixing. In critical applications, always use the Safety Cord accessory.

—Avoid any contact with aggressive solvents and cleaning products.

—It is not possible for Buttonfix to warn the consumer about every possible danger related to use of the Button-fix and the consumer must use his or her own good judgment when installing and using the Button-fix.

## The button

The blue Button has been specially designed for use with the Type 2 Fix. It can be used with  $\varnothing 5\text{mm}$  countersunk wood screws **(A)**, or  $\varnothing 6.2\text{mm}$  Varianta Euro screws **(B)** (to fit  $\varnothing 5\text{mm}$  pilot holes). Check with your panel supplier which screw type is best for your application.

### Screw retaining feature (C)

The blue Button has a unique screw-retaining feature, to hold the screw during assembly — simply twist the screw by half a turn into the Button as shown. Varianta Euro screws should be screwed through the Button, before attempting to screw to the panel.

## Safety Cord accessory

In situations where safety is an issue, install two Safety Cords **(D)**, one to each Fix in the top corners.

An additional Button is used to capture the loop on the Safety Cord, installed adjacent to the fixing Button. To remove the panel completely, ease the Safety Cord off the Button. Each safety cord can support 10kg (22lbs).

**Please note that the Safety Cord accessory needs to be ordered separately from the Button-fixes.**

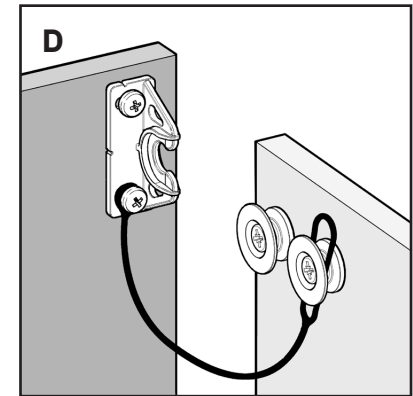
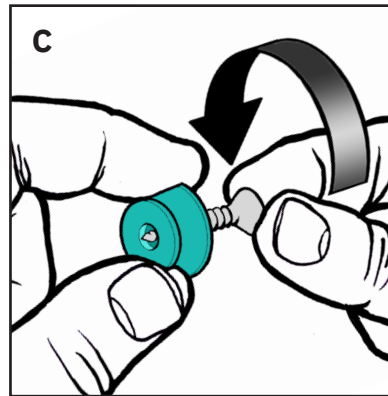
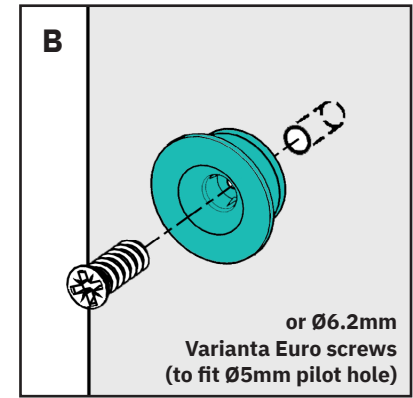
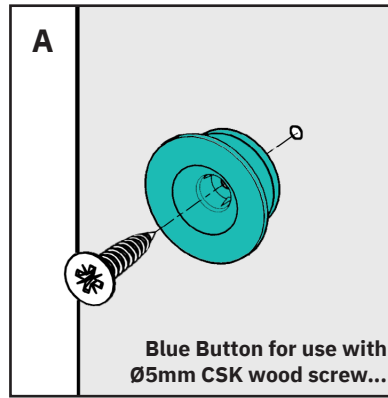

## Installation

The Type 2 Fix can be mounted to suit an overflying panel or internal panel arrangement.

### 1. Overflying panel

The Type 2 Fix is attached to the removable panel as shown in the diagrams on the right, with fixing centres measured 13mm in from the surface onto which the Button is fixed.

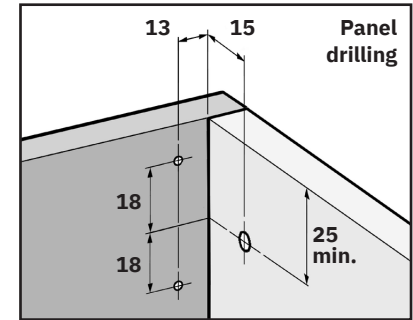
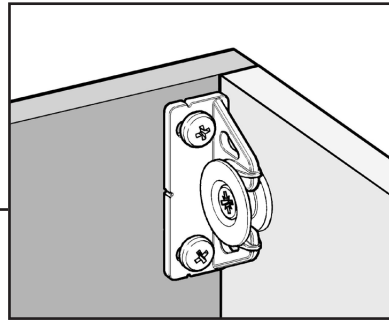

### 2. Internal panel

The Type 2 Fix is attached to the removable panel as shown in the diagrams on the right, with fixing centres measured 12mm in from the edge of the panel, giving a 1mm clearance between the panel and the surface onto which the Button is fixed.

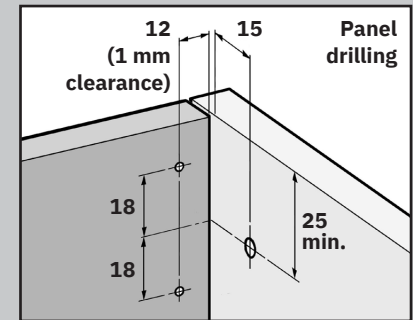
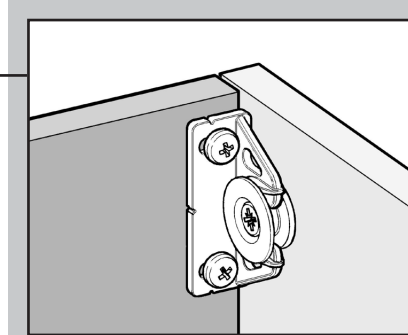

### A useful tip

The holes for mounting the Fix are slotted to allow a small degree of adjustment.

First, tighten the fixing screws gently, such that the Fix can move with some resistance. The panel may then be installed, positioned and removed, before finally tightening the screws fully – this facilitates precise alignment of the panel.

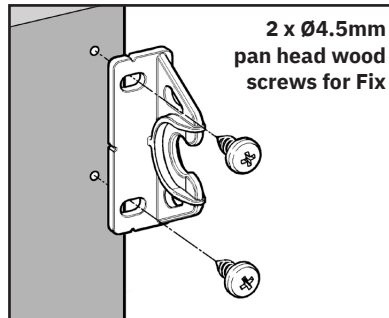

## Fix marker accessory

The Fix marker accessory aids swift panel mounting, reducing the need for measuring and marking out.

### 1. Overflying panel

The marker and Button-fix are assembled as shown in diagram (A) and used to locate the Button (B).

After fixing the Button, the removeable panel is then pushed firmly against the marker spikes (C), giving an accurate position for the Fix (D).

### 2. Internal panel

The marker can also be used for internally mounted panels, but the tabs must be removed as shown (E).

The Button is marked out and fixed at the required position (this will depend on the panel thickness), before installing the marker tool and pushing the panel firmly against the marker spikes (F).

Tip: use some adhesive tape to stop the assembly rotating on the Button.

**Please note that the Fix marker accessory needs to be ordered separately from the Button-fixes.**

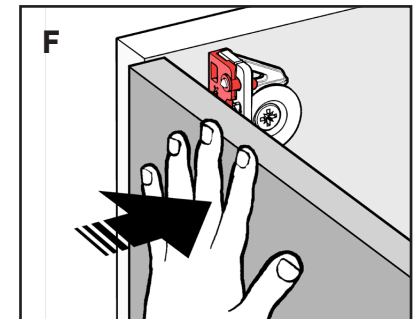
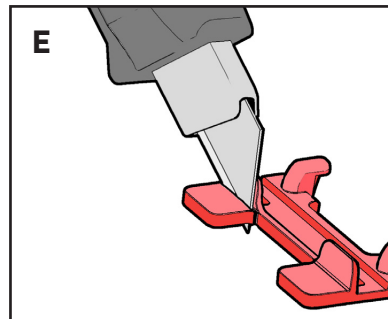
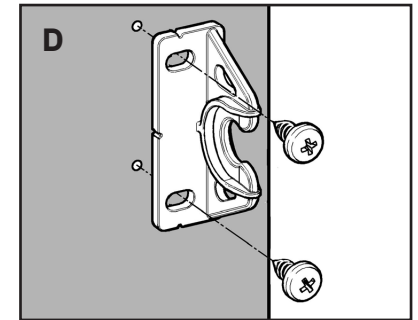
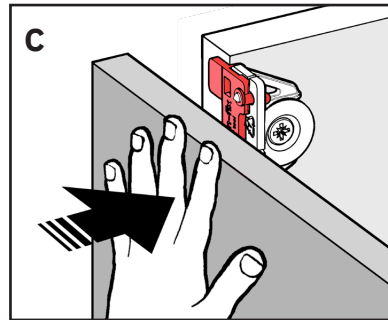
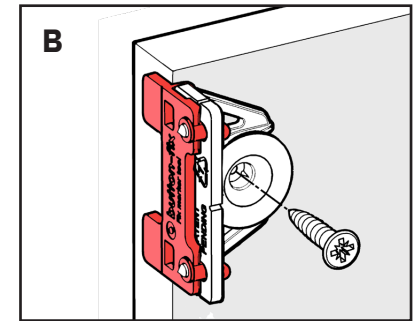
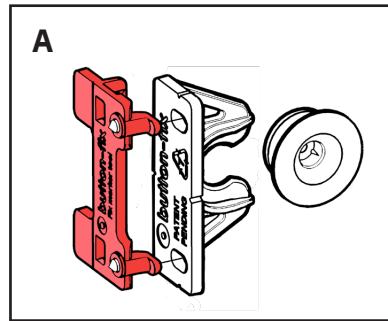

## A simple hinge

When a Type 2 Fix is used to hold an internal panel, the panel may rotate about two Fixes provided that there is sufficient clearance around the panel.

In this way, the Type 2 Fix can be used to create simple pivoted access panels.

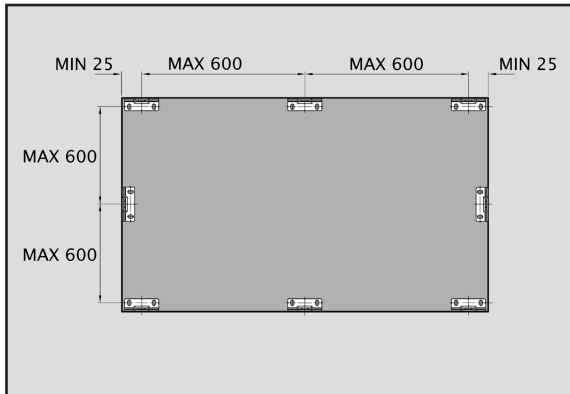
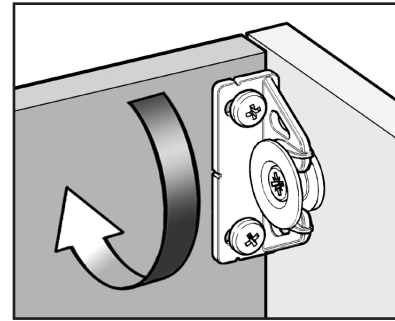



## Suggested layout

As an approximate guide, we suggest that Type 2 Fixes are spaced no greater than 600mm apart. This may vary, dependent upon the mass and stiffness of the panel.

The Type 2 Fixes may be installed in a vertical or horizontal orientation, or a combination of both (as shown).

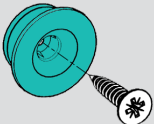
## Screw fixings guide

Product/configuration	Panel thickness/ material	Screw type	net thread length	Notes
<b>Type 2 Button</b>  	<b>15 to 18mm thick</b> Plywood, MDF, MFC	Ø5.0 × 20mm CSK (#10 × 0.75")	11.9mm	Spax or similar Timco (product code: 50020CLAF)
	<b>18mm or greater</b> Plywood, MDF, MFC	Ø5.0 × 25mm CSK (#10 × 1")	16.9mm	Spax or similar. Screwfix (product code: 913PV) Timco (product code: 50025CLAF)
		M5 CSK machine screw (#10)		User-defined length e.g. M5 × 40mm Screwfix (product code: 7363J)
	<b>10 to 12mm thick</b> Plywood, MDF, MFC	Varianta Ø7.8 CSK × 13.5mm	6.5mm	Häfele (product code: 013.15.724) <b>Requires Ø5mm pilot hole</b>
	<b>12 to 15mm thick</b> Plywood, MDF, MFC	Varianta Ø7.8 CSK × 16mm	9mm	Häfele (product code: 013.15.733) <b>Requires Ø5mm pilot hole</b>
<b>Type 2 Fix</b>  	<b>12 to 15mm thick</b> Plywood, MDF, MFC	Ø4.0 / Ø4.5 × 12mm pan head (#8/#9 × 0.5")	9mm	
	<b>15 to 18mm thick</b> Plywood, MDF, MFC	Ø4.0 / Ø4.5 × 16mm pan head (#8/#9 × 0.625")	13mm	
	<b>18mm or greater</b> Plywood, MDF, MFC	Ø4.0 / Ø4.5 × 20mm pan head (#8/#9 × 0.75")	17mm	
		M4 pan head machine screw (#8)		User-defined length. Always use with a washer
	<b>8 to 12mm thick</b> Plastic, HPL	#8 × 0.375" pan head Plas-Fix 60	6.4mm	TR Fastenings (product code: TR00032557-103) <b>Requires Ø4mm pilot hole</b>
	<b>12 to 15mm thick</b> Plastic, HPL	#8 × 0.5" pan head Plas-Fix 60	9.4mm	TR Fastenings (product code: TR00032555-103) <b>Requires Ø4mm pilot hole</b>
	<b>12 to 15mm thick</b> Plywood, MDF, MFC	Varianta Ø9 CSK × 13.5 mm	8.8mm	Häfele (product code: 013.15.626) <b>Requires Ø3mm pilot hole</b>

Suggestions are based on screws available in the UK which have been tested for compatibility with Type 1 Button-fix. Screws from other suppliers may also be suitable but have not been validated by Buttonfix Limited – **always perform your own tests for critical applications.**

## Specifications

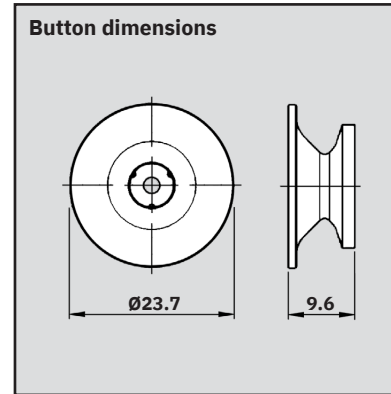
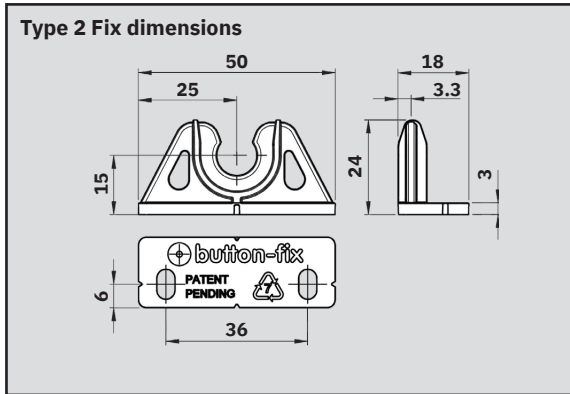

**Material:** DuPont Zytel® Nylon 66 (Fix)  
Nylon PA6 (Button)

**Guide loads:** Wall panel with 4 x Fixes = 50 kg max.

**Never use Type 2 on ceiling panels.**

—Advice on panel loads is given with the proviso that the screws and substrate are properly matched, and all other instructions complied with. For critical applications it is essential to perform your own tests.

—Disengagement force for a single Type 2 Fix is approximately 7 kg

**Origin:** Manufactured in the UK

**Buttonfix Limited**  
Unit A, 1 Britton Street  
London, EC1M 5NW

**T:** +44 (0)20 8150 7190

**E:** [info@button-fix.com](mailto:info@button-fix.com)

**EU Authorised Representative:**

AR Experts BV  
Boeingavenue 209  
1119PD Schiphol-Rijk  
The Netherlands

**[button-fix.com](http://button-fix.com)**